

T E C H N I C A L D A T A S H E E T F O R**BOARD DIFFUSERS**

TYPE: PT 660 AND PT 1100

- Flooded board made of environmentally-friendly polypropylene with glass fiber.
- Simple and fast installation with use of grommet or saddle for DN 90, 110 and 114 tube
- Compatibility with other systems
- Possibility for changing from DN 64 tube diffusers to board with higher efficiency

PT 660/1100 fits Supratec with both body and membrane**MATERIALS**

Membranes in high quality EPDM with low plasticizer or Silicone – compression-molded = 100 % quality control. Plate and ring in recyclable PP.

The PT board diffuser offers a solid construction and impressive performance data. The common connections and optional adapters make it an extremely attractive product to retrofit quickly to outdated and less efficient technologies.

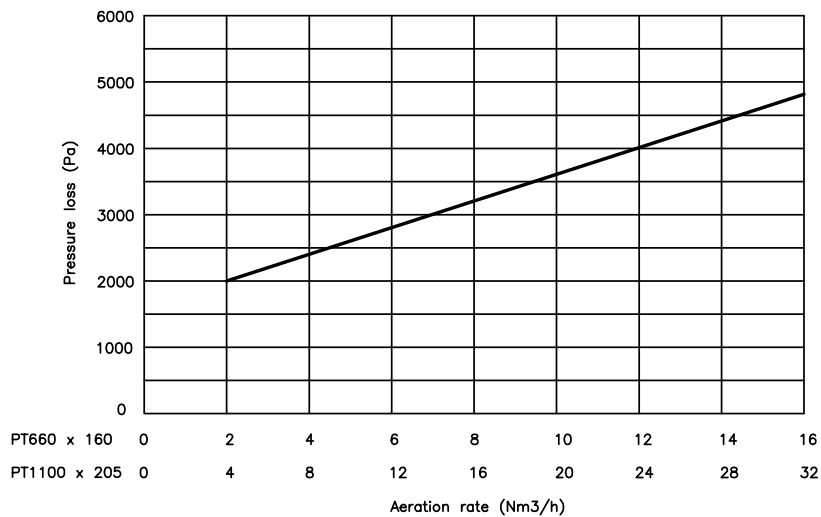
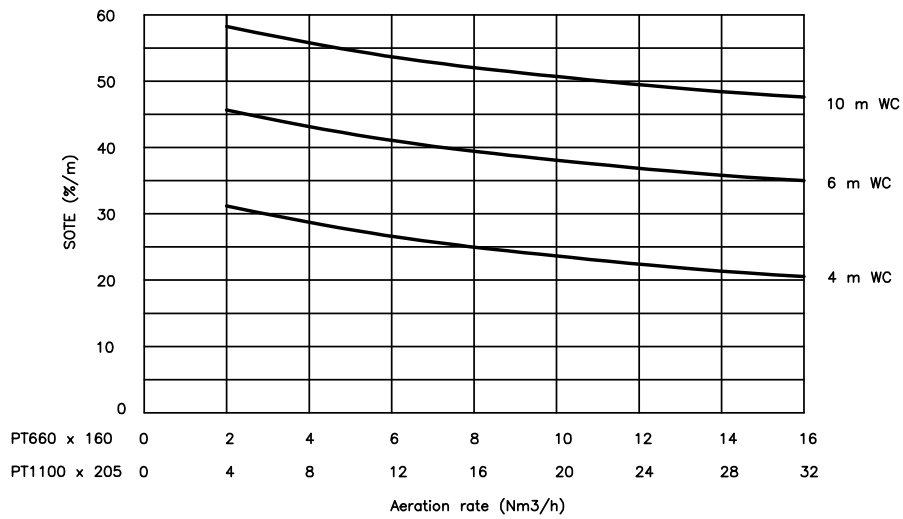
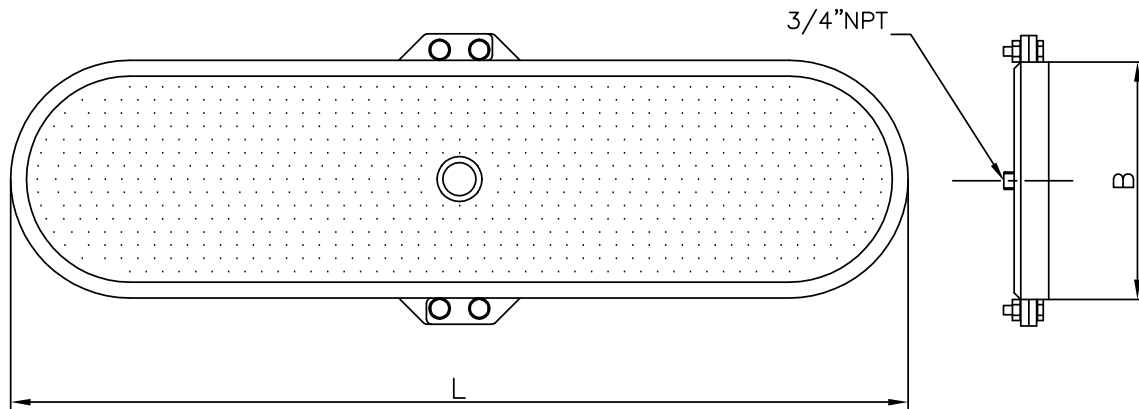

Type	Width (∅B)	Length (L)	Design Flow	Flow Range	Active Surface Area	Weight
PT660	180 mm	680 mm	5–9 Nm3/h	0–12 Nm3/h	0.1 m2	1.6 kg
PT1100	200 mm	1120 mm	10–14 Nm3/h	0–20 Nm3/h	0.2 m2	3.1 kg